

Captive Screw Type 5 8-32 Thread

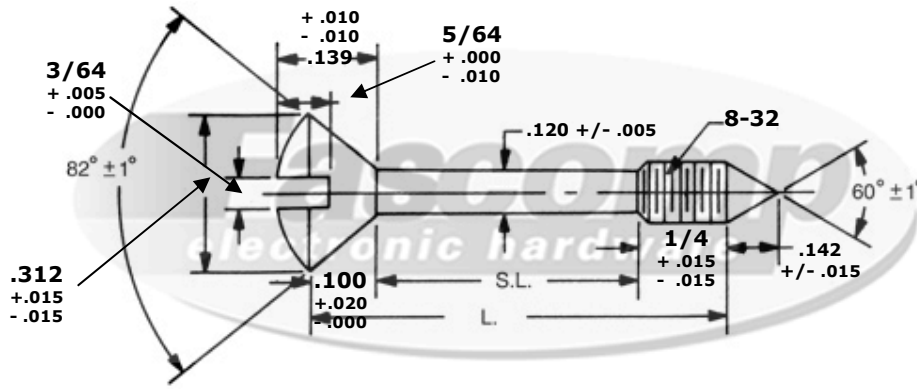

Create a part number:

Length	Material	Finish
FCXXXX	XX	XX

Captive Screws - 8-32 Thread			
✓	FCXXXX	Length (L)	S.L. REF
	FC0926	1/2	9/64
	FC0927	9/16	13/64
	FC0928	5/8	17/64
	FC0929	11/16	21/64
	FC0930	3/4	25/64
	FC0931	13/16	29/64
	FC0932	7/8	33/64
	FC0933	15/16	37/64
	FC0934	1	41/64
	FC0935	1-1/16	45/64
	FC0936	1-1/8	49/64
	FC0937	1-3/16	53/64
	FC0938	1-1/4	57/64
	FC0939	1-5/16	61/64
	FC0940	1-3/8	1-1/64
	FC0941	1-7/16	1-5/64
	FC0942	1-1/2	1-9/64

Material	
✓ Material Code (XX)	
B	Brass
S	Steel
SS	Stainless Steel

✓ Compatible Finish (XX)	
B, S, SS	0 - Plain
B, S	5 - Nickel Plate (QQ-N-290)
B, S	12 - Zinc Clear (ASTM-B-633)
B, S	16 - Electro Tin (MIL-T-10727 TYPE 1)
SS	20 - Passivation (MIL-F-14072D)
B, S, SS	26 - Black Oxide
B, S	28 - Zinc Yellow (ASTM-B-633)

Tolerances Unless otherwise Specified
 .xxx +/- .005
 .xx +/- .010
 Angular +/- 1 Degree
 Linear +/- .005
Break all sharp edges

Source Control Drawing:
 To be produced by
 Fascomp Electronic Hardware



This document is the property of Fascomp Inc. and shall not be reproduced, distributed, or used as a basis for manufacturing without written permission from Fascomp Inc.